

# **IMPORTANT**

**Engineering Bulletin #112  
Limit Board Version 2 (LIMITV2) Software  
Use on Microflite Microflite Plus, Ultra, and  
Ultra 2000 Controllers Using Digital  
Encoders with Speed Reference for Pattern  
Clamping**

## **Motion Control Engineering**

**New York Office  
84-00 72nd Drive Unit F  
Glendale NY 11385  
(718) 417-3131**

## Section 1

### Limit Board Version 2 Software

O. Thompson has released an enhanced version of Limit board software for use on the Microflite Ultra 2000 Control System. This software may also be used on MicroFlite Plus and Ultra controllers, meeting the conditions explained further. This new software utilizes a rotary encoder to monitor the position of the car in the hoistway. By constantly monitoring the position of the car, the Limit board will have the ability to gently slow and stop the car if it is approaching either the top or bottom of travel at a speed greater than the normal deceleration rate. This deceleration rate is slightly greater than the normal deceleration rate, and will not be detectable by any passengers who may be in the car.

### Hardware Requirements

The Version 2 (LIMITV2) software requires a Limit board with Revision level 2.0 or greater. If an earlier version of hardware is used, the board could intermittently trip.

## Section 2

### Limit Board Wiring

This version of software requires an input from a rotary encoder attached to the hoist motor. If this software is installed on an existing controller, an encoder feed must be wired into the board at connector J9. Also, if the controller's existing Limit board did not have the speed reference signal wired to it, it must be installed for the board to function properly.

Make sure there is a jumper on JP6.

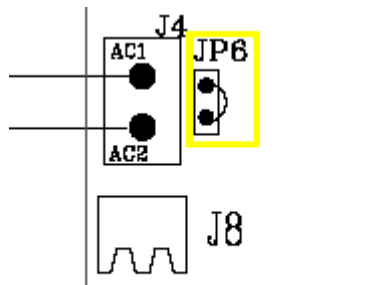

Refer to Figure 1 below for the proper wiring of the board.

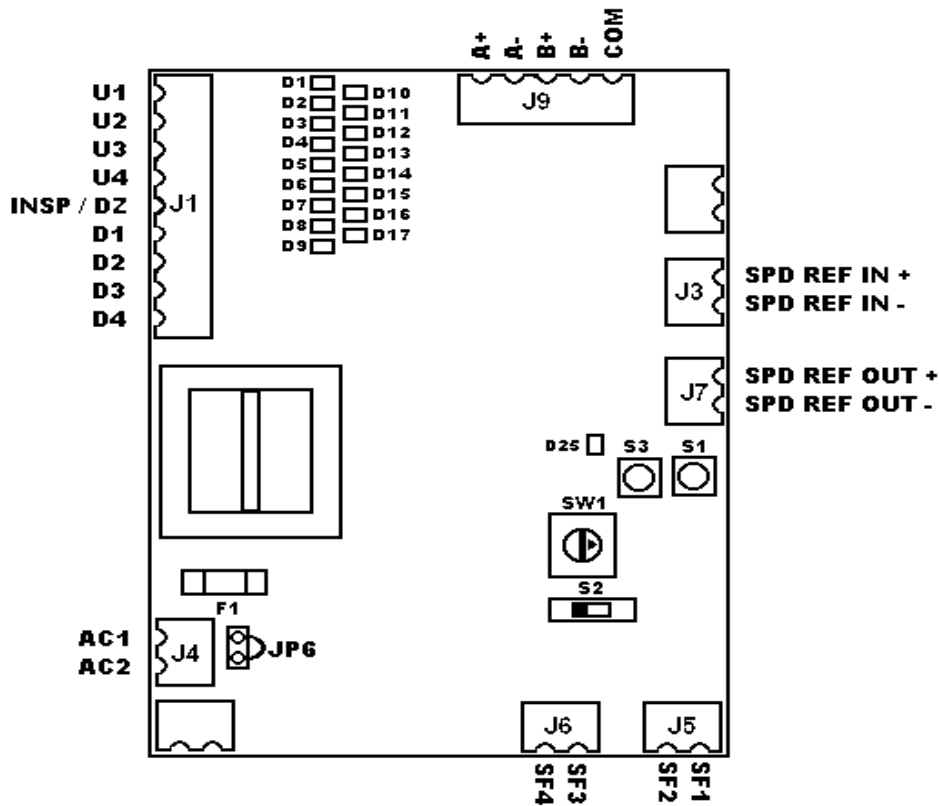

Figure 1

### Section 3

#### Limit Switch Distances

After the board is installed and wired, it may be desirable to relocate the existing limit switches in the hoistway. Leaving the switches in their present position may cause the Limit board to limit the car's maximum speed if power is removed or if the board is reset at a position away from a terminal floor. This will occur because the Limit board has lost its position, and it has determined that the maximum safe speed at which the car can operate is less than contract speed. The maximum safe speed is the speed at which the Limit board can safely slow and stop the car based on the setting of the slowdown switches and the maximum measured deceleration rate.

**Relocating the switches is not mandatory, but may be desired for optimum operation of the board.**

To determine the distance which the limit switches should be set to it is first necessary to determine the maximum deceleration rate of the car. To do this, access the "Motion Parameters" Menu. Check the "Acceleration Rate" parameter. The largest value saved here will be the maximum deceleration rate. Typically, this will be between 2.0 ft/s<sup>2</sup> and 4.0 ft/s<sup>2</sup>. Referring to the following tables, find the table that has a deceleration rate equal to or greater than the

largest programmed acceleration rate value. For speeds not divisible by 100 (i.e.: 350 FPM), use the distance values from the next greater speed.

Table 1 - Acceleration Rate [ 3.0 ft/s <sup>2</sup>				
Car Speed	1SU / 1SD	2SU / 2SD	3SU / 3SD	4SU / 4SD
200			3'	1' 6"
300			5' 6"	3'
400			9'	3'
500			13' 6"	3'
600		18' 6"	12'	3'
700		24'	16'	3'
800	31'	22'	15'	3'
900	38' 6"	28'	17'	3'
1000	46' 6"	33'	20'	3'
1100	55' 6"	39'	23'	3'
1200	65'	45'	26'	3'
1300	76'	53'	30'	3'
1400	87'	59'	33'	3'
1500	99' 6"	67'	37'	3'

Table 2 - Acceleration Rate $\mu$ 3.0 but [ 3.5 ft/s <sup>2</sup>				
Car Speed	1SU / 1SD	2SU / 2SD	3SU / 3SD	4SU / 4SD
200			3'	1' 6"
300			5' 6"	3'
400			8' 6"	3'
500		12'	7'	3'
600		16' 6"	10'	3'
700		22'	12'	3'
800	28'	19'	19'	3'
900	34' 6"	23'	13'	3'
1000	41' 6"	29'	16'	3'
1100	49' 6"	33'	18'	3'
1200	58'	39'	21'	3'
1300	67' 6"	45'	24'	3'
1400	77' 6"	53'	28'	3'

1500	88'	59'	31'	3'
------	-----	-----	-----	----

Table 3 - Acceleration Rate $\mu 3.5$ but [ 4.0 ft/s <sup>2</sup>				
Car Speed	1SU / 1SD	2SU / 2SD	3SU / 3SD	4SU / 4SD
200			2' 6"	1' 6"
300			5'	3'
400			7' 6"	3'
500		11'	7'	3'
600		15'	9'	3'
700		20'	11'	3'
800	25'	17'	10'	3'
900	31'	22'	11'	3'
1000	37' 6"	27'	15'	3'
1100	44' 6"	31'	17'	3'
1200	52' 6"	37'	20'	3'
1300	61'	41'	22'	3'
1400	70'	47'	25'	3'
1500	79' 6"	53'	28'	3'

Table 4 - Acceleration Rate $\mu 4.0$ ft/s <sup>2</sup>				
Car Speed	1SU / 1SD	2SU / 2SD	3SU / 3SD	4SU / 4SD
200			2' 6"	1' 6"
300			4' 6"	2'
400			7'	3'
500		10' 6"	7'	3'
600		14'	9'	3'
700		18' 6"	11'	3'
800	23'	17'	10'	3'
900	28' 6"	21'	12'	3'
1000	34' 6"	25'	14'	3'
1100	41'	29'	16'	3'
1200	48'	33'	18'	3'
1300	56'	39'	21'	3'
1400	64'	43'	23'	3'
1500	72' 6"	49'	26'	3'

The values in these tables are suggested distances. If the switches are set closer to the floor, the car will not have enough distance to slow down from contract speed at the maximum acceleration rate measured during the learn procedure. Setting the switches further than these values will have no effect on the operation of the board.

#### Section 4

##### Limit Board Set Up

Before the Limit board learn procedure is performed, it is necessary to program the car speed. Locate the rotary switch “SW1” on the Limit board. Using the chart below, locate the contract speed of the car. SW1 will be set based on the car speed. If the contract speed of the car is not divisible by 100 (for example, 350 FPM), S2 will be used to add 50 FPM to the programmed car speed.

Car Speed	SW1	Car Speed	SW1	Car Speed	SW1
100	1	600	6	1100	B
200	2	700	7	1200	C
300	3	800	8	1300	D
400	4	900	9	1400	E
500	5	1000	A	1500	F

Set SW1 to the value specified above. If 50 FPM needs to be added, place S2 in the right most position. If not, S2 must remain in the left most position. If the SW1 or S2 settings have been modified while the board was powered up, you must cycle power to the board.

The Limit board requires a learn procedure for calibration. With the car on inspection, place it somewhere near the center of the hoistway, away from all terminal floor slowdown switches. Prior to doing the learn procedure the inspection speed must be set up to its highest possible setting, as allowed by the inspection speed potentiometer adjustment (e.g. Ultra 2000). Verify that all of the limit switches are turned on by checking the LED’s on the board. Use the chart below to determine which LED corresponds to which limit.

Limit	LED	Limit	LED
U1	D1	D1	D5
U2	D2	D2	D6
U3	D3	D3	D7
U4	D4	D4	D8

LED D9 should be turned off. It will come on when the car is on Automatic operation with the doors closed. Due to the circuit, when placing some controllers on inspection operation, while the door is closed, LED D9 will not turn off. If this is the case on your controller, disconnect the INSP/DZ wire (pin 5 on connector J1) for the time being.

To place the board in the learn mode, press S3 and then press and release S1. Release S3. LED D25 (DIAGNOSTIC LED) will be blinking rapidly (on 1/8 second, off 1/8 second). Also, the D10, D11, D12, D15 and D17 LED's will be lit.

Run the car up and down on inspection. Confirm that the car speed does not exceed 100 FPM.

Run the car up on inspection about 5 feet. D15 will turn on, indicating the encoder input presence. With the car running, press and release S3. D10, D11 and D15 will turn off.

D25 will now be on continuously, indicating that the inspection learn procedure was done correctly, and the board is in normal operation.

Lower the inspection speed back to its original, desired setting. If you had to disconnect the INSP/DZ wire (pin 5 on connector J1), please reconnect it at this time.

**Attention:** The high-speed learn trip must be done following the inspection learn and not the other way around. If you have to redo the inspection learn, then please make sure to also follow it by a high-speed learn. If your inspection learn has already been completed and there is no need to redo it, you can repeat the high-speed learn trip as many times as needed, without having to redo the inspection learn.

Next, the Limit board must be set up for high-speed operation.

Bring the car to the lowest landing door zone on inspection operation. Disable the doors, and place the car on Automatic operation. Press and hold switch S3. Press and release switch S1. Release switch S3. D25 (DIAGNOSTIC LED) will begin blinking rapidly, and D10, D11 and D12 will be illuminated.

Do a high-speed run to the top floor. D15 will turn on, indicating the board has detected the encoder input at connector J9. D16 will also turn on, indicating that the board has detected the presence of the speed reference input at connector J3. After the car stops, D10 will turn off. This confirms that the board has recorded the positions of the top and bottom limit switches and learned the contract speed of the car. If D10 or D11 LED's are flashing, the board has detected a fault. Refer to Section 5 for an explanation of the fault.

The next step of the learn procedure requires the car to make a one floor run in the up direction. To do this, run the car down to a floor toward the middle of the hoistway. This floor must be of typical height for the building. Make a one floor run in the up direction.

Run the car back to the top floor. Once the car stops, D11 will turn off, indicating that the Limit board has measured and saved the maximum deceleration of the car.

Run the car back down to the bottom floor. After the car stops, D12 will turn off, and D25 (DIAGNOSTIC LED) will stop blinking and remain on. This will indicate the learn procedure has been completed successfully.

## Section 5

### Learn Procedure Faults

If the Limit board detects a fault during the learn procedure it will begin flashing the D10 or D11 LED's. Refer to the following table for an explanation of the faults and corrective action.

LED	Fault Description	Corrective Action
D10 flashing 1 second on, 1 second off	Speed Feedback Fault	The Limit board has not detected the Speed Feedback signal from the encoder. Check the encoder wiring at connector J9.
D11 flashing 1 second on, 1 second off	Encoder Wiring Fault	The Limit board has detected a problem with the Speed Feedback signal. The most likely cause is a wiring error of the encoder signal at connector J9. Check the wiring and confirm that it is wired as shown in Figure 1.
D10 & D11 flashing 1 second on, 1 second off	Speed Reference Fault	The Limit board has not detected a Speed Reference signal at connector J3. Confirm that J3 is wired as shown in Figure 1. If the problem persists, replace the Limit board.

## Section 6

### Limit Board Testing

After the learn procedure has been performed, run the car on automatic operation. The car should run at contract speed and decelerate normally. Run the car to the top and bottom floor and confirm that LED D25 on the board stays on continuously. If it starts to flash at any time, the board has detected the car was approaching a terminal floor too fast, and has brought the car into the floor. If this occurs, the board has not been set up correctly, and the learn procedure must be performed again.

Once it has been confirmed that the car runs normally, it is necessary to test the board. **BEFORE THE BOARD IS TESTED, IT MAY BE NECESSARY TO PREVENT THE CAR SAFETY AND/OR COUNTERWEIGHT SAFETY FROM APPLYING.** To do this, disable the safety devices by tying the safety arm down so it will not apply if the car or counterweight strikes the buffer.

If the customer is not doing this then they are running the risk that the mechanical safety could apply, and if it is the type that requires the car to be moved up to reset, they may be in a position where the car cannot be moved. In this situation, releasing the mechanical safety can be quite a problem.

After the safeties have been disabled, run the car on automatic to a floor in the center of the hoistway. Access the Parameters menu on the MPU. Go to the "Floor Landing Values" menu.



Change the bottom floor to “000002.” Change the top floor value to a value 10,000 counts above its present setting. Save these changes and exit the Parameters menu.

**Section 6.1**

**NTS Testing**

Place a car call for the bottom floor. The processor will not attempt to slow the car down, and the Limit board will slow and stop the car in the door zone of the bottom floor. Place a car call for the top floor. Again, the processor will not attempt to slowdown, and the Limit board will slow and stop the car in the door zone of the top floor.

**Section 6.2**

**ETS Testing**

Run the car back to the center of the hoistway. After the car stops, remove connectors J3 and J7 from the limit board. Using two short pieces of wire, jump J3-1 to J7-1 and J3-2 to J7-2. Place a car call for the bottom floor. The car will not attempt to slowdown, and the Limit board will attempt to slow the car down. When the car does not respond, the Limit board will trip, removing power from the hoist motor and brake, stopping the car. This will occur when the speed of the car exceeds a value at which the Limit board can safely slow and stop the car. Place a car call for the top floor. Again, the car will not attempt to slowdown, and the Limit board will trip and stop the car.

**WHEN FINISHED, RE-ENABLE THE SAFETIES DISABLED AT THE BEGINNING OF THIS TEST.**

Cycle power to the controller and the car can be returned to service.

**Section 7**

**Limit Board Faults**

After the car is placed in operation, some of the diagnostic LED’s may blink, indicating that a fault has occurred. Refer to the following Table for an explanation of the faults.

LED	Fault Description	Corrective Action
D25 flashing 2 seconds on, 2 seconds off – pattern clamping; ½ second on, ½ second off – immediate stop, safety circuit opened D14/D15 solidly on - up/down direction when error occurred D10-D13 solidly on - up/down limit status when error occurred	Terminal Slowdown Occurrence	The Limit board has detected that the car was approaching a terminal floor at a speed greater than it should have. The board initiated a slowdown and stopped the car.
D10 flashing 1 second on, 1 second off	1) Speed Feedback Loss or 2) J1	1) The Limit board has detected that the car has been running, but no Speed Feedback has been present. This will cause the Limit board to trip, removing

	Connector Limits Missing on Power-up	power from the hoist motor and brake. 2) The Limit board has detected that the car has not been running and the limit inputs to J1 are missing.
D11 flashing 1 second on, 1 second off	Slowdown Sequence Fault	The Limit board has detected that the slowdown switches opened in a sequence other than that which was seen during the learn procedure. This could be caused by faulty wiring or a bad limit switch.

If you have any questions about this or any other O. Thompson device, please contact our Technical Support Department at (718) 417-3131.